

MOSO® Bamboo N-durance Outdoor Decking

installation instructions

before installation

- Waterlogging under the decking must be avoided by preparing a water permeable ground structure. This can be achieved by sand layers and gravel dispersion above.
- Use cement/stone tiles 40-50 mm thick or pedestals, to support the sub frame (see drawing).
- Place a root barrier under the tiles or pedestals to prevent weeds growing under the decking.
- Install the decking boards with a slope of 1-2% to enable water to run off the surface.
- The decking with the curved surface BO-DTC191G-C can be installed without a slope. Thanks to the curved surface, fast drainage from the boards is guaranteed.
- Ensure good ventilation of the decking by keeping at least 20 mm gap from walls and objects and avoid closing the decking at the sides. The gap between the boards must be open to ensure unrestricted ventilation.
- When the surface / soil underneath the decking is not fast drying, there should be at least 100 mm distance between the decking and the surface underneath.
- Use sub frame joists with the minimum size of 40x60 mm. MOSO® recommends the use of MOSO® Bamboo X-treme® Sub frame joists, which are specifically produced for use in combination with our decking products. Alternatively, suitable joists are those with the same durability class as the decking; aluminum sub frame joists, stable hardwood joists or pine joists. When using hardwood or pine as joists, make sure the moisture content of these joists is below 12%. Avoid direct contact with the soil.
- MOSO® Sub frame joists can be installed without gaps, connecting the joists with screws and glue suited for outdoor use. Other sub frame joists should be installed according to the instructions of the supplier.
- In order to create a stable deck frame, the outsides of the frame have to be connected at regular intervals to the ground/structure below. Alternatively cross bracing can be applied.
- Install the boards on sub frame joists with 462.5 mm space between the joists (centre-to-centre) so each board is supported by 5 joists. Always install the ends of the boards exactly on the joist. Distance between sub frame joist depends on category of use. For non-residential use, please contact MOSO®.
- If a random installation pattern is preferred, make sure that the sub frame joists (centre-to-centre) are no more than 300 mm apart.
- Always install cut off boards on at least 3 sub frame joists.

please note

- The MOSO® Bamboo N-durance Decking board is a natural product, which varies in colour, grain and appearance. Colour can quickly change from caramel to a lighter colour, depending on the maintenance schedule.
- Small cracks and splinters on the surface and on the ends of the boards can arise from the different drying characteristics of the surface and cross cut ends. The surface will also get rougher over time. This phenomenon is normal for most wood species and is minimized for this product by its unique 'Outdoor-Density®' production method. Cracks on the board ends can be further minimized by applying sealer to the ends of the boards (see 'the installation').
- Splinters and roughness can be removed by cleaning the surface of the decking with the silicon carbide broom or machine disk which MOSO® supplies. The surface will become smoother and splinters are removed.
- Dimensional changes or cupping of the boards can occur after installation. This phenomenon is normal for most wood species and is minimized for this product by its unique Outdoor-Density® production process.
- When using the flat side of the boards as surface please note that deformation under influence of climate will be significantly more visible. Some deformation and/or cupping of the material can occur. This phenomenon is normal for outdoor exposed wood and cannot be grounds for a claim.

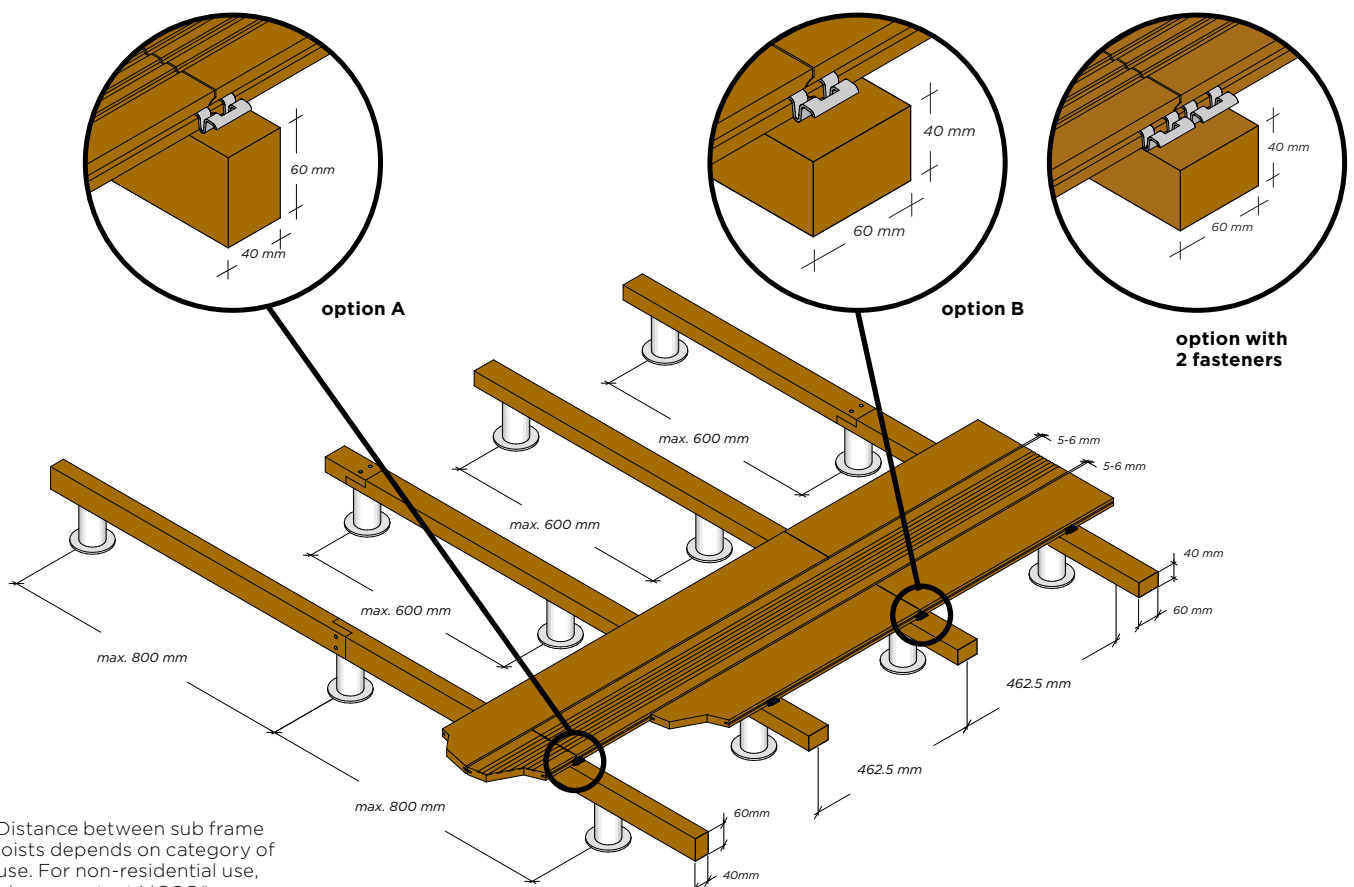

Distance between sub frame joists depends on category of use. For non-residential use, please contact MOSO®.

MOSO® Bamboo N-durance Outdoor Decking

installation instructions

the installation

- Keep at least 5-6 mm gap between the boards (in width direction). With MOSO® Fastener installation this is automatically the case.
- Because of the stability of the boards and the end-match system no expansion gap is needed on the ends of the boards.
- Every cut end has to be treated with board end sealer, to prevent water penetration. A sealer is available from MOSO.
- Yearly maintenance with Woca Exterior Wood Oil is required to maintain the warm caramel colour and the anti-surface fungi resistance. For decking oiled with Woca Exterior Wood Oil, it is recommended to perform the first maintenance after 3-4 months.

installation with fasteners

- Determine the surface side of the boards (grooved or flat surface).
- Use the MOSO® Asymmetric Fasteners in the following sequence:
 - Press fastener with hooked side in the edge groove of one board.
 - Pre-drill the joist screw holes 30 mm deep. On bamboo joists: use a 3.5 mm wide drill bit 110 mm long.
 - Fully tighten the screw. Always screw vertically to the joist. Apply low torque with slow screwing speed on the screwing machine. Perform some tests for correct torque and speed adjustment before full installation.
 - Install every following board by sliding it under the waved side of the fasteners.
- Use approx. 20 fasteners per m² (137 mm) or 17 fasteners per m² (155 mm). When the tongue and groove are connected on the joist, use 1, preferably 2 fasteners, 1 for every board (see drawing options A/B).
- For bamboo or wood joists only use the included stainless steel decking screws (4.5 x 30 mm).

screw down installation

- Determine the surface side of the boards (grooved- or flat surface).
- Pre-drill the screw holes 20 mm from the side of the board. Be sure to pre drill with a large enough drill (80% of screw diameter) to avoid cracking of the decking.
- Always screw both sides (left and right in the width direction) of the board.
- Use at least A2 stainless steel quality decking screws (approx. 5 x 50 mm).

cleaning and maintenance

MOSO® Bamboo N-durance Decking is pre-oiled, double sided, with Woca Exterior Wood Oil.

- Clean and maintain the decking at least one time per year with Woca Exterior Wood Cleaner and silicon carbide broom or -disk. Depending on climate and use it may be necessary to perform cleaning and maintenance more than once per year.
- Remove the dirt water residue on the boards with clean water and let the surface dry.
- Apply 1-2 new layers of Woca Exterior Wood Oil. When a new finish is not applied once a year, depending on the situation, the decking will change to a lighter colour. Superficial fungi may also develop.
- It is advisable to keep the decking free from dust and dirt as much as possible (clean by broom regularly).

storing

Store MOSO® Bamboo N-durance in a cool and dry place away from direct sunlight, and protected from weather influences, dirt and dust.

additional note

Whilst all due care is taken to ensure the accuracy of the installation instructions, individual circumstances (location, sub floor and installation procedures) may vary and are beyond the manufacturer's control. In case of doubt, therefore, consult the distributor. Always follow the local building code.

These instructions are subject to change. For the latest version visit www.moso-bamboo.com/n-durance

Copyright © Nothing from this text may be reproduced without the prior permission in writing from MOSO International BV.

MOSO® Bamboo N-durance Outdoor Decking

cleaning & maintenance

maintenance with Woca

The surface of decking is weathered under influence of wind, rain, frost and sunshine (UV). As a result, the surface turns grey, dirty and cracks/splinters will appear. WoodCare Denmark (Woca) has developed different outdoor cleaning- and maintenance products. Woca Exterior Wood Cleaner loosens dirt and removes green growth from the surface, without damaging it. Woca Exterior Wood Oil protects the bamboo decking and bringing back the warm caramel colour.

cleaning

- Soak MOSO® Bamboo N-durance with plenty of water. If possible use a garden hose. Do not use high-pressure cleaners.
- Mix Woca Exterior Wood Cleaner with water in the ratio 1:2 and apply it. If the decking is extremely dirty, exterior cleaner may be used undiluted. Clean the decking with a silicon carbide broom or machine disk (see accessories).
- Scrub the soaked material lengthwise following the bamboo grain until the material appears clean.
- If the decking has been installed flat side up, first scrub under an angle of 45 degrees before scrubbing in the length direction. When using a machine disk this is not necessary.
- Repeat the cleaning if necessary. Clean the surface carefully with water.
- Leave MOSO® Bamboo N-durance to dry for approx. 24 hours. The material must be completely dry before oil treatment can be done.

application of oil

- Apply in dry weather only. Avoid direct sunlight and high temperatures.
- Always make sure the decking is clean, dry, free of dust and dirt.
- Stir the oil thoroughly before use. Apply an even thin coat of oil with a brush.
- The oil is cream-coloured when it is wet.
- After a few minutes, the material has an oily appearance as the water is evaporating.
- Wipe off any excess oil with clean cotton cloths after no more than 5-10 minutes.
- Take particular care to remove excess oil from joints and grooves.
- Repeat the above process.
- When the material is dry, it may be polished with a polishing pad or polishing machine to ensure an extra hard-wearing surface. It takes 24 to 48 hours for the oil to harden thoroughly, depending on weather conditions and outdoor temperature. The material should not be exposed to water during this period.
- Pay attention to the ends of the joists and cut ends of the boards, which tend to absorb more water, and finish well to prevent water penetration. A sealer is available from MOSO®.

theoretical consumption

- Mix Woca Exterior Wood Cleaner with water in the ratio 1:2 and apply it. If the decking is extremely dirty, exterior cleaner may be used undiluted.
- Woca Exterior Wood Oil: 12 - 15 m² / litre.

maintenance of flat surface

Please be aware of the fact that on the flat surface, irregularities in the surface (e.g. cracks, splinters) are more visible than on the grooved surface. With regular maintenance with Woca Exterior Wood Oil, this will be reduced.

risk of self-ignition

Due to the risk of self-ignition it is important that oil-wetted cloths are soaked in water and are disposed in a tightly closed container after use. For more details, check the instructions of the finish supplier.



MOSO® Bamboo N-durance Outdoor Decking

user information

appearance and colour

MOSO® Bamboo N-durance is a natural product, which can vary in colour, grain and appearance. Colour will change over time depending on the maintenance schedule. The boards have a warm caramel colour when installed, which turns into a lighter colour several weeks after installation.

If a warm caramel colour is preferred, maintenance should be done with Woca Exterior Wood Oil or a similar waterbased finish. See for further details the installation and maintenance instructions:

www.moso-bamboo.com/n-durance

Yearly maintenance with Woca Exterior Wood Oil will be required to maintain the warm caramel colour and the anti-surface fungi resistance. For decking oiled with Woca Exterior Wood Oil it is recommended to perform the first maintenance after 3-4 months.

MOSO® Bamboo N-durance shows similarity to other hardwoods in grain and structure. The characteristic bamboo nodes however can still be recognized and give the product a special and lively look.

swimming pool

If MOSO® Bamboo N-durance Outdoor Decking is to be used around swimming pool areas, the following has to be taken into account: MOSO® Bamboo N-durance is a natural (wood like) product. As with any wooden product used outdoors, there is always a risk of formation of splinters, however splinters from MOSO® Bamboo N-durance are normally smaller than (tropical) hard wood splinters. A regular application of a finish (more frequently necessary around swimming pools) is required to reduce the formation of splinters.

Furthermore, regular maintenance with the silicon carbide broom or -disk is required to effectively remove splinters and smoothen the surface. The boards must be installed in such a way that the surface water cannot flow directly into the pool.

Also bear in mind that treated swimming pool water contains salt and chlorine which can cause the boards around the pool to "weather" and become bleached faster than the boards in areas not exposed to the swimming pool water.

normal phenomena

Cracks on the surface and on the ends of the boards can occur due to the different drying characteristics of the surface and board ends. This does not affect the stability or durability of the board.

The surface side of the boards will become rougher over time and can form (small) splinters as a result of continuous water absorption and desorption due to dry and wet weather periods. Dimensional change or cupping of the boards can occur after installation. These phenomena are normal for most hardwood species and MOSO® Bamboo N-durance.

After installation, there might be some bleeding or leaching of colour from the bamboo material when it gets wet, e.g. when it rains. This possible bleeding is typical for wood and will disappear over time. The brownish liquid can easily be cleaned from the Bamboo N-durance material, however controlled water drainage and prevention of splash water is required to prevent any discoloration of surrounding or underlying building components.

maintenance of flat surface

When using the flat side of the boards as top surface please note that deformation under influence of climate may be more visible. Some deformation and/or cupping of the material can occur. This phenomenon is normal for outdoor exposed wood and cannot be grounds for a claim.

dry condition



wet condition

